

AQ 100
 Claw clutch
 Zeppa joint
 Spline prop shaft
 Rubber hub prop

Oil:
 Gear Oil
 API GL-5, SAE 90
 Qty PZ Nr. 17451: 2 liters (2.11 US qts)
 Qty PZ Nr. 17452 - 20421: 2.5 liters (2.64 US qts)

Ratio:
 1.66:1

AQ 100
 PZ Nr. 20422 - 45350
 Cone clutch
 Zeppa joint
 Shear pin prop

Oil:
 Gear Oil
 API GL-5, SAE 90
 Qty: 2.5 liter (2.64 US qts)

Ratio:
 1.66:1

AQ 100B
 PZ Nr. 500000 -
 Cone clutch
 Universal joint
 Shear pin prop

Oil:
 Same as engine
 Qty: 3.1 liters (3.27 US qts)

Ratio:
 1.66:1

AQ 170R
 High speed lower unit
 Quick change lower gears

Oil:
 Same as engine
 Qty: 19.0 liters (20.1 US qts)

Ratio:
 1.225:1
 1.41:1

AQ 750
 Diesel Sterndrive
 Steerable Lower Unit

Oil:
 Same as engine
 Qty: 2.0 liters (2.1 US qts)

Ratio:
 1.9:1

AQ 200
 Electro mechanical tilt
 PZ Nr. 200001-225738

Oil:
 Same as engine
 Qty: 2.0 liters (2.1 US qts)

Ratio:
 B = 1.59:1
 C = 1.35:1
 D = 1.35:1

AQ 250
 Electro mechanical tilt
 PZ Nr. 2500001-2519326

Oil:
 Same as engine
 Qty: 2.2 liters (2.32 US qts)

Ratio:
 A = 1.35:1
 B = 1.61:1
 C = 1.89:1
 D = 2.15:1

AQ 270

Oil:
 Same as engine
 Qty: 2.2 liters (2.32 US qts)

Ratio:
 B = 1.61:1
 C = 1.89:1
 D = 2.15:1

AQ 270E
 Power trim/tilt

Oil:
 Same as engine
 Qty: 2.2 liters (2.32 US qts)

Ratio:
 1.61:1
 1.89:1
 2.15:1

AQ 270E
 High speed lower unit
 Quick change lower gears
 Surface piercing propeller

Oil:
 Same as engine

Ratio:
 1.18:1
 1.26:1
 1.41:1
 1.45:1

AQ 270 TE
 Power trim/tilt
 High speed lower unit
 Quick change lower gears
 Surface piercing propeller

Oil:
 Same as engine

Ratio:
 1.18:1
 1.26:1
 1.41:1
 1.45:1

AQ 275
AQ 275A
 PZ Nr. 27XXXXXX
 290 upper gear head
 Electro mechanical tilt

Oil:
 Same as engine
 Qty: 2.2 liters (2.32 US qts)

Ratio:
 2.15:1

AQ 280
 PZ Nr. 28XXXXXX
 Lower unit housing

Oil:
 Same as engine
 Qty: 2.6 liters (2.74 US qts)

Ratio:
 1.61:1
 1.89:1
 2.15:1

AQ 280T
 Power trim/tilt

Oil:
 Same as engine
 Qty: 2.6 liters (2.74 US qts)

Ratio:
 1.61:1

AQ 280 PT
 Power trim

Oil:
 Same as engine
 Qty: 2.6 liters (2.74 US qts)

Ratio:
 1.61:1
 1.89:1
 2.15:1

AQ 280E
 High speed lower unit
 Quick change lower gears
 Surface piercing propeller

Oil:
 Same as engine

Ratio:
 1.45:1

AQ 285
AQ 285A
 Electro mechanical tilt
 Power steering
 Upper gear head
 A = 290

Oil:
 Same as engine
 Qty: 2.6 liters (2.74 US qts)

Ratio:
 1.61:1

AQ 280-DP
 Introduction of DuoProp®
 Type A, B, C or J propellers

Oil:
 Same as engine or
 Gear Oil
 API GL-5, SAE 90
 Qty: 2.7 liters (2.85 US qts)

Ratio:
 1.95:1
 2.30:1

AQ 280-DP/PT
 Dual hydraulic cylinders
 Type A, B, C or J propellers

Oil:
 Same as engine
 Qty: 2.7 liters (2.85 US qts)

Ratio:
 1.61:1
 1.95:1
 2.30:1

AQ 290
AQ 290A
 New transom shield

Oil:
 Same as engine
 Qty: 2.6 liters (2.74 US qts)

Ratio:
 1.61:1
 1.89:1
 2.15:1

AQ 290-DP
AQ 290A-DP
 Transom shield
 Double bearing box
 Hook up fork
 Type A, B, C or J propellers

Oil:
 Same as engine
 Qty: 2.7 liters (2.85 US qts)

Ratio:
 1.61:1
 1.95:1
 2.30:1

SP-A
 Top cover
 Shift cover

Oil:
 Same as engine
 Qty: 2.6 liters (2.74 US qts)

Ratio:
 1.61:1
 1.89:1
 2.15:1

SP-A1
 Top cover
 Intermediate shaft and nut
 Intermediate housing
 Ball bearing
 Universal joint
 Spline sleeve
 Prop shaft with nut
 Line cutter

Oil:
 Same as engine
 Qty: 2.6 liters (2.74 US qts)

Ratio:
 1.61:1
 1.89:1
 2.15:1

SP-A2
 Sliding sleeve, steel
 Gear set
 Cover

Oil:
 Same as engine or
 Gear Oil
 API GL-5 SAE 75W-90
 Qty: 2.7 liters (2.85 US qts)

Ratio:
 1.95:1
 1.89:1
 2.30:1

SP-C
 *Sliding sleeve, steel
 †Sliding sleeve (brass)
 Intermediate housing
 Hydraulic cylinder
 Gear set
 Cover

Oil:
 †Same as engine
 *Synthetic Gear Oil
 API GL-5 SAE 75W-90
 Qty: 2.6 liters (2.74 US qts)

Ratio:
 *1.61:1
 †1.89:1
 ‡2.15:1

SP-E
 Upper gear (DP-E)
 New color

Oil:
 Synthetic Gear Oil
 API GL-5 SAE 75W-90
 Qty: 2.6 liters (2.74 US qts)

Ratio:
 1.61:1

DP-A
 Top cover
 Shift cover
 Type A, B, C or J propellers

Oil:
 Same as engine
 Qty: 2.7 liters (2.85 US qts)

Ratio:
 1.95:1
 1.89:1
 2.30:1

DP-A1
 Sliding sleeve, brass
 Cover
 Ball bearing
 Universal joint
 Spline sleeve
 Intermediate shaft
 Intermediate housing
 Type A, B, C or J propellers

Oil:
 Same as engine
 Qty: 2.7 liters (2.85 US qts)

Ratio:
 1.78:1
 1.95:1
 2.30:1

DP-A2
 Sliding sleeve, steel
 Cover
 Gear set
 Type A, B, C or J propellers

Oil:
 Synthetic Gear Oil
 API GL-5 SAE 75W-90
 Qty: 2.7 liters (2.85 US qts)

Ratio:
 1.78:1
 1.95:1
 2.30:1

DP-B
 Sliding sleeve, steel
 Type A, B, C or J propellers

Oil:
 Synthetic Gear Oil
 API GL-5 SAE 75W-90
 Qty: 2.7 liters (2.85 US qts)

Ratio:
 1.78:1
 1.95:1
 2.30:1

DP-B1
 Cover
 Ball bearing
 Universal joint
 Intermediate housing
 Type A, B, C or J propellers

Oil:
 Synthetic Gear Oil
 API GL-5 SAE 75W-90
 Qty: 2.7 liters (2.85 US qts)

Ratio:
 1.78:1
 1.95:1
 2.30:1

DP-C
 Sliding sleeve, steel
 Cover
 Intermediate housing
 Hydraulic cylinder
 Transom shield
 Type A, B, C or J propellers

Oil:
 Synthetic Gear Oil
 API GL-5 SAE 75W-90
 Qty: 2.7 liters (2.85 US qts)

Ratio:
 1.78:1
 1.95:1
 2.30:1

DP-C1
 Propeller shaft
 Propeller cone
 Type A, B, C or J propellers

Oil:
 Synthetic Gear Oil
 API GL-5 SAE 75W-90
 Qty: 2.7 liters (2.85 US qts)

Ratio:
 1.78:1
 1.95:1
 2.30:1

DP-D
 Propeller shaft
 Diesel sterndrive
 Type A, B, C or J propellers

Oil:
 Synthetic Gear Oil
 API GL-5 SAE 75W-90
 Qty: 2.7 liters (2.85 US qts)

Ratio:
 1.78:1
 1.95:1
 2.30:1

DP-D1
 Propeller shaft
 Propeller cone
 Type A, B, C or J propellers

Oil:
 Synthetic Gear Oil
 API GL-5 SAE 75W-90
 Qty: 2.7 liters (2.85 US qts)

Ratio:
 1.68:1
 1.95:1
 2.30:1

DP-E
 New color
 Type A, B, C or J propellers

Oil:
 Synthetic Gear Oil
 API GL-5 SAE 75W-90
 Qty: 2.7 liters (2.85 US qts)

Ratio:
 1.68:1
 1.78:1
 1.95:1
 2.32:1

DP-G
 Upper gear (DP-E/DPX-A)
 Cover upper gear
 Lower gear
 Exhaust outlet
 Type A, B, C or J propellers

Oil:
 Synthetic Gear Oil
 API GL-5 SAE 75W-140
 Qty: 3.1 liters (3.27 US qts)

Ratio:
 1.59:1
 1.66:1
 1.66:1

DPX-S
DPX-S1
 Sliding sleeve, brass
 X-act™ steering
 Gear set
 Thru-hub exhaust
 Type E propellers

Oil:
 Synthetic Gear Oil
 API GL-5 SAE 75W-90
 Qty: 2.0 liters (2.06 US qts)

Ratio:
 1.59:1
 1.66:1
 1.78:1

DPX-R
 X-act™ steering
 Vertical shaft
 Shot peened lower housing gears
 Type E propellers

Oil:
 Synthetic Gear Oil
 API GL-5 SAE 75W-90
 Qty: 2.0 liters (2.06 US qts)

Ratio:
 1.47:1
 1.51:1
 1.59:1
 1.68:1
 1.78:1

DPX-A
 DP-G Upper Gear Train
 DPX-R Lower Unit
 X-act™ steering
 Thru-hub exhaust
 Type E propellers

Oil:
 Synthetic Gear Oil
 API GL-5 SAE 75W-90
 Qty: 2.6 liters (2.75 US qts)

Ratio:
 1.47:1
 1.59:1
 1.66:1
 1.78:1

VPMP Drive
 New Transom Shield
 Thru Hub exhaust

Oil:
 Synthetic Gear Oil
 API GL-5 SAE 75W-90
 Qty: 2.1 liters (2.22 US qts)

Ratio:
 1.60:1
 1.66:1
 1.85:1

SX-S
 Lower Unit, shortened
 Vertical shaft, shortened
 Upper Unit
 Spray Rails

Oil:
 Synthetic Gear Oil
 API GL-5 SAE 75W-90
 Qty: 2.1 liters (2.22 US qts)

Ratio:
 1.51:1
 1.60:1
 1.66:1
 1.85:1
 1.97:1

SX-C1

Trim Sender (three wire)

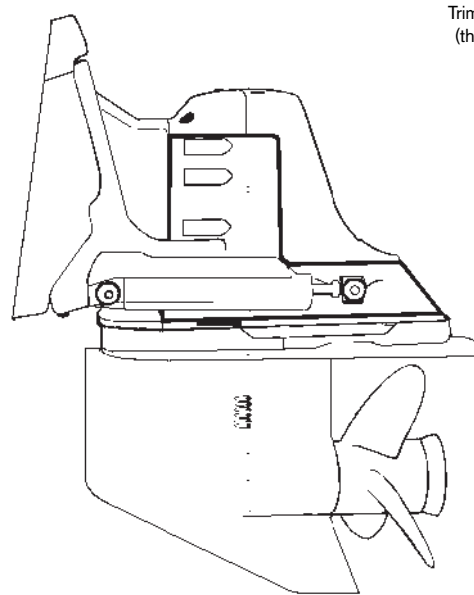

Ratio:
1.43:1
1.51:1
1.60:1
1.66:1
1.79:1
1.85:1
1.97:1

Oil:
Synthetic Gear Oil
API GL-5 SAE 75W-90
Qty: 2.1 liters (2.22 US qts)

SX-C2

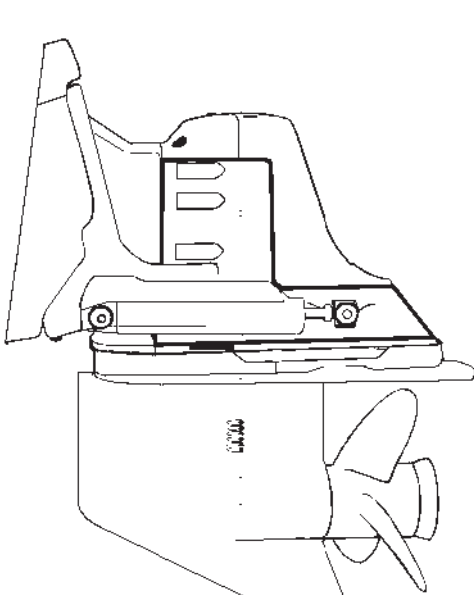

Ratio:
1.43:1
1.51:1
1.60:1
1.66:1
1.79:1
1.85:1
2.18:1

Oil:
Synthetic Gear Oil
API GL-5 SAE 75W-90
Qty: 2.1 liters (2.22 US qts)

SX-RT1

Diesel Applications
Coated exhaust passage

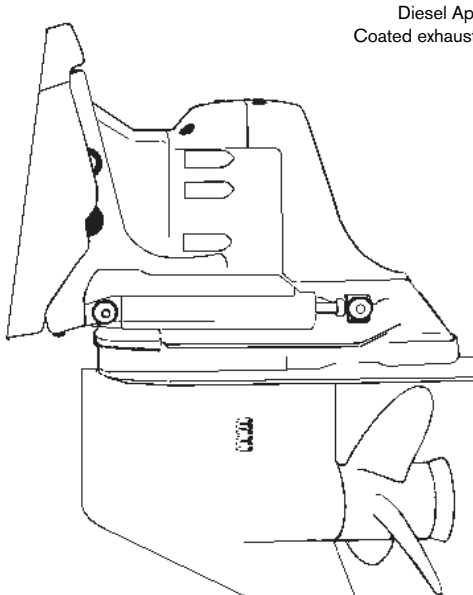

Ratio:
1.66:1
1.79:1
1.85:1
2.18:1

Oil:
Synthetic Gear Oil
API GL-5 SAE 75W-90
Qty: 2.1 liters (2.22 US qts)

SX-RT2

Diesel Applications

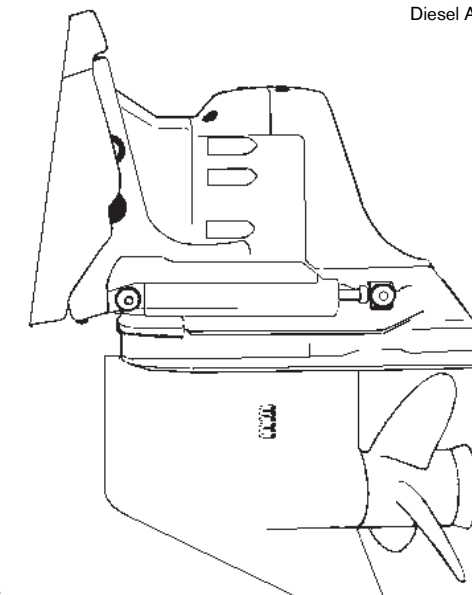

Ratio:
1.66:1
1.79:1
1.85:1
2.18:1

Oil:
Synthetic Gear Oil
API GL-5 SAE 75W-90
Qty: 2.1 liters (2.22 US qts)

SX-M

Water tube
Trim/Tilt pump
Trim/Tilt cylinders

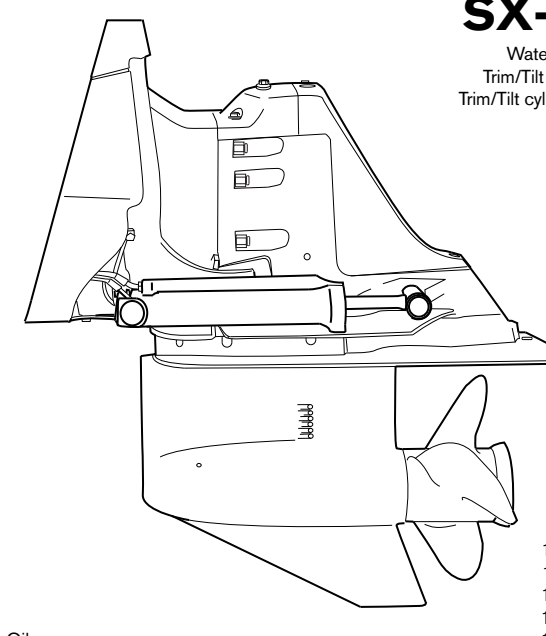

Ratio:
1.43:1
1.51:1
1.60:1
1.66:1
1.79:1
1.85:1
2.18:1

Oil:
Synthetic Gear Oil
API GL-5 SAE 75W-90
Qty: 2.1 liters (2.22 US qts)

SX-MTD

Diesel Applications
Coated exhaust passage

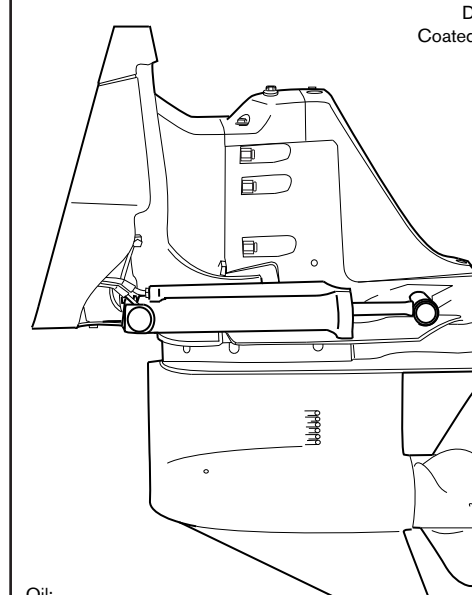

Ratio:
1.79:1
1.85:1
2.18:1

Oil:
Synthetic Gear Oil
API GL-5 SAE 75W-90
Qty: 2.1 liters (2.22 US qts)

DP-S

VPMP Duo-Prop®
Thru-hub exhaust
Type D, F or I propellers

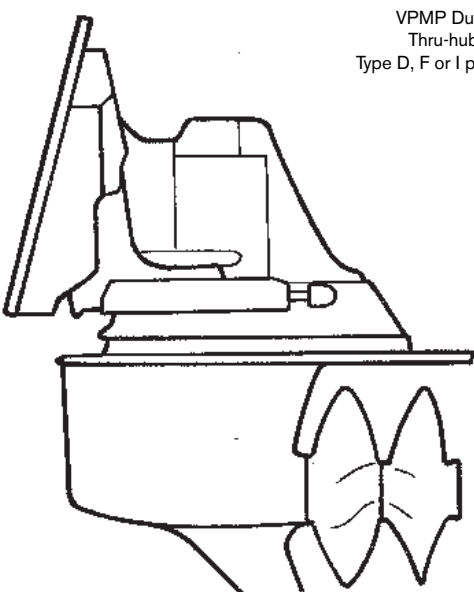

Ratio:
1.68:1
1.78:1
1.95:1
2.30:1

Oil:
Synthetic Gear Oil
API GL-5 SAE 75W-90
Qty: 2.4 liters (2.53 US qts)

DP-S1

Thru-hub exhaust
Type D, F or I propellers

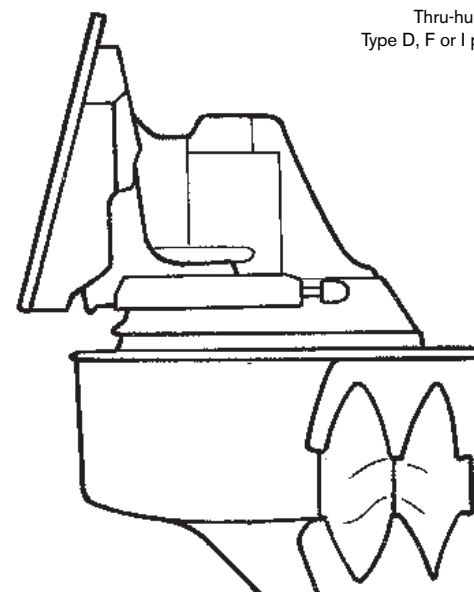

Ratio:
1.68:1
1.78:1
1.95:1
2.30:1
2.32:1

Oil:
Synthetic Gear Oil
API GL-5 SAE 75W-90
Qty: 2.4 liters (2.53 US qts)

DP-SM

Trim/Tilt Pump
Trim/Tilt cylinders
Water tube
Type D, F or I propellers

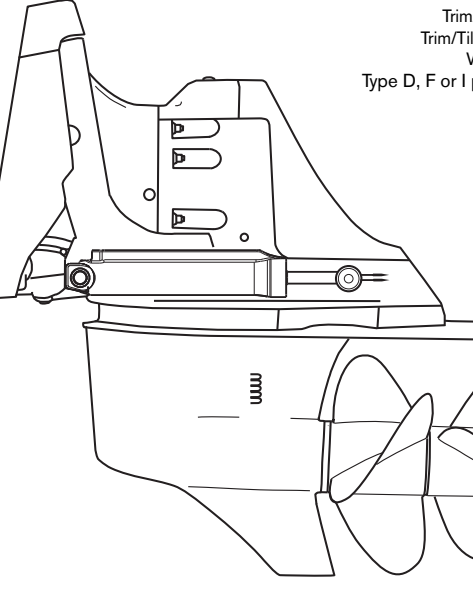

Ratio:
1.68:1
1.78:1
1.95:1
2.32:1

Oil:
Synthetic Gear Oil
API GL-5 SAE 75W-90
Qty: 2.4 liters (2.53 US qts)

DP-SMTD

Diesel applications
Coated exhaust passage
Type D, F or I propellers

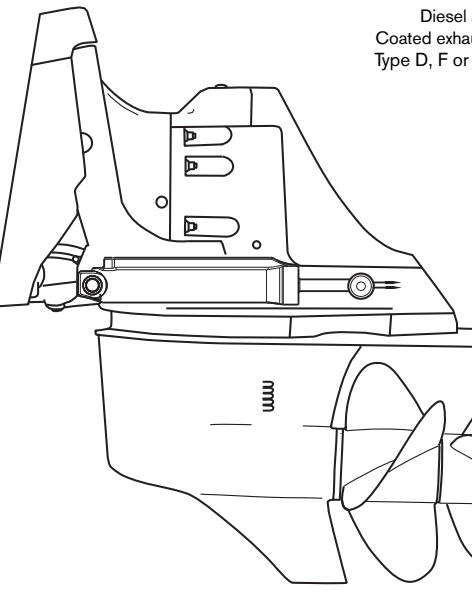

Ratio:
1.79:1
1.95:1
2.32:1

Oil:
Synthetic Gear Oil
API GL-5 SAE 75W-90
Qty: 2.4 liters (2.53 US qts)

DP-SMTD1

Diesel applications
Coated exhaust passage
Type D, F or I propellers

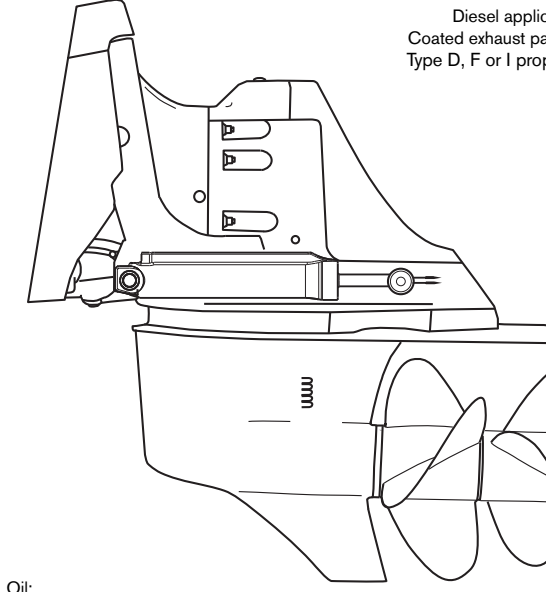

Ratio:
1.95:1

Oil:
Synthetic Gear Oil
API GL-5 SAE 75W-90
Qty: 2.4 liters (2.53 US qts)

XDP-B

Composite outer shell
Remote oil reservoir
Type X, D, or F Propellers

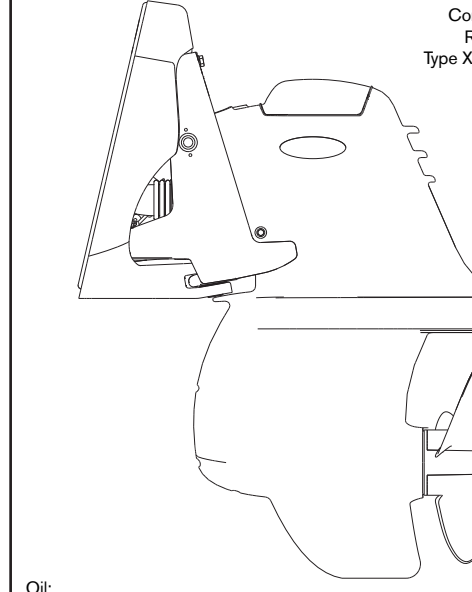

Ratio:
1.78:1
1.96:1

Oil:
Synthetic Gear Oil
API GL-5 SAE 75W-90
Qty: 2.15 liters (2.27 US qts)

SX-A

Redesigned
Transom Shield
Integrated trim pump
New Trim/Tilt cylinders

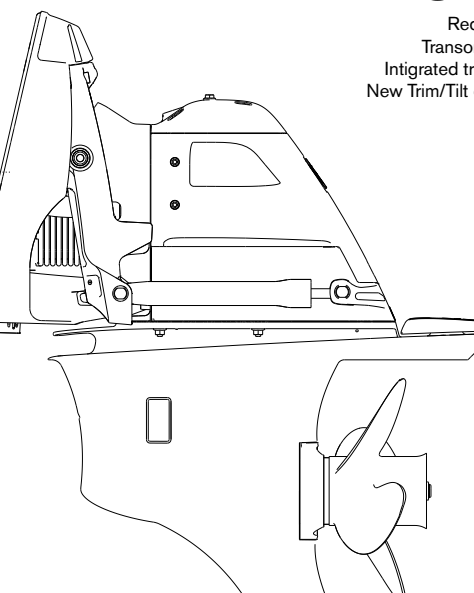

Ratio:
1.43:1
1.51:1
1.60:1
1.66:1
1.79:1
1.89:1
1.97:1
2.18:1

Oil:
Synthetic Gear Oil
API GL-5 SAE 75W-90
Qty: 2.44 liters (2.58 US qts)

DPS-A

Redesigned
Transom Shield
Integrated trim pump
New Trim/Tilt cylinders
Type D, F or I propellers

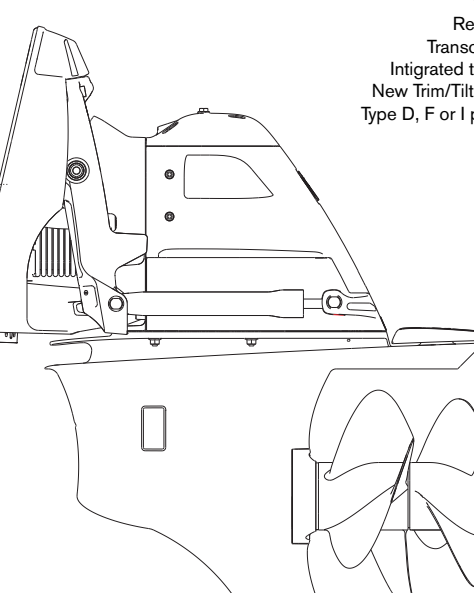

Ratio:
1.68:1
1.78:1
1.95:1
2.11:1
2.32:1

Oil:
Synthetic Gear Oil
API GL-5 SAE 75W-90
Qty: 2.25 liters (2.38 US qts)

DPS-A OX

Henkel® Coating
ACP Standard
Type D, F or I propellers

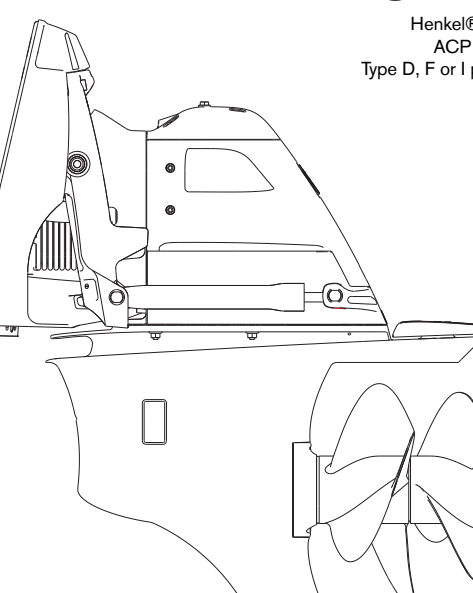

Ratio:
1.68:1
1.78:1
1.95:1
2.11:1
2.32:1

Oil:
Synthetic Gear Oil
API GL-5 SAE 75W-90
Qty: 2.25 liters (2.38 US qts)

DPS-B

Helical splined propshaft
Redesigned propeller hub
Type IH or FH propellers

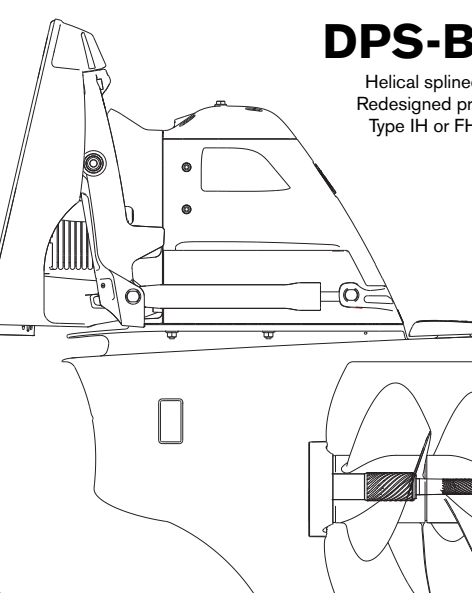

Ratio:
1.68:1
1.78:1
1.95:1
2.11:1
2.32:1

Oil:
Synthetic Gear Oil
API GL-5 SAE 75W-90
Qty: 2.25 liters (2.38 US qts)

DPS-B1 OX

Helical splined propshaft
Henkel® Coating
Redesigned propeller hub
Type IH or FH propellers

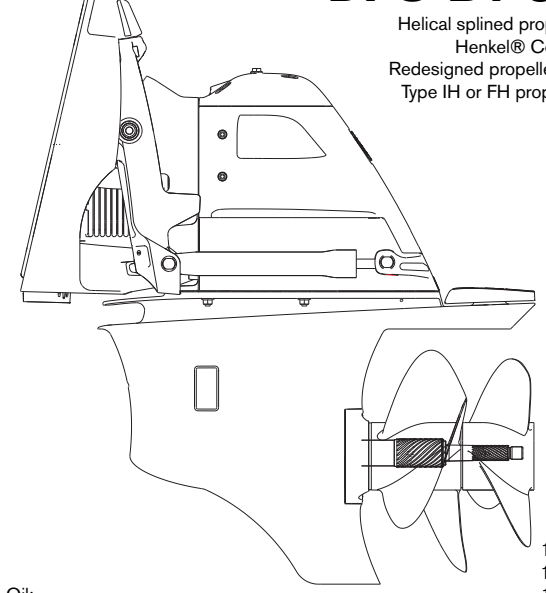

Ratio:
1.68:1
1.78:1
1.95:1
2.11:1
2.32:1

Oil:
Synthetic Gear Oil
API GL-5 SAE 75W-90
Qty: 2.25 liters (2.38 US qts)

DPS-D1

Silent Shift
Henkel® Coating
Redesigned propeller hub
Type IH or FH propellers

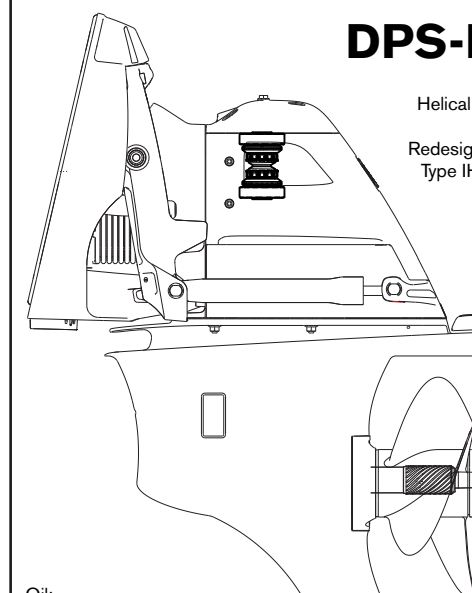

Ratio:
1.68:1
1.78:1
1.95:1
2.11:1
2.32:1

Oil:
Synthetic Gear Oil
API GL-5 SAE 75W-90
Qty: 2.25 liters (2.38 US qts)

FWD-B1

Forward Facing drive
Helical splined propshaft
Type K Propellers

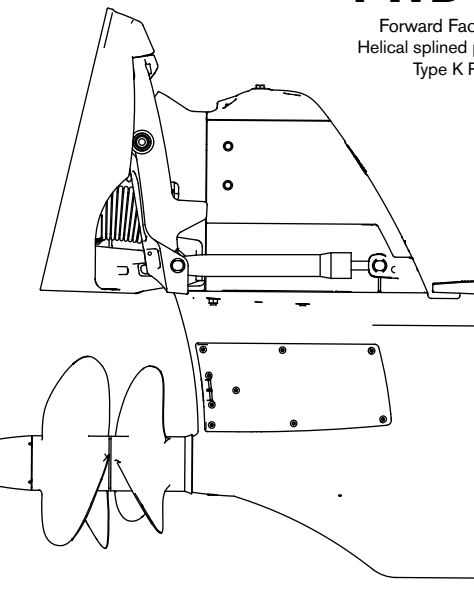

Ratio:
1.95:1
2.14:1
2.32:1

Oil:
Synthetic Gear Oil
API GL-5 SAE 75W-90
Qty: 2.8 liters (3.0 US qts)

FWD-B2

Forward Facing drive
Helical splined propshaft
Narrow Spray Plate
Type K Propellers

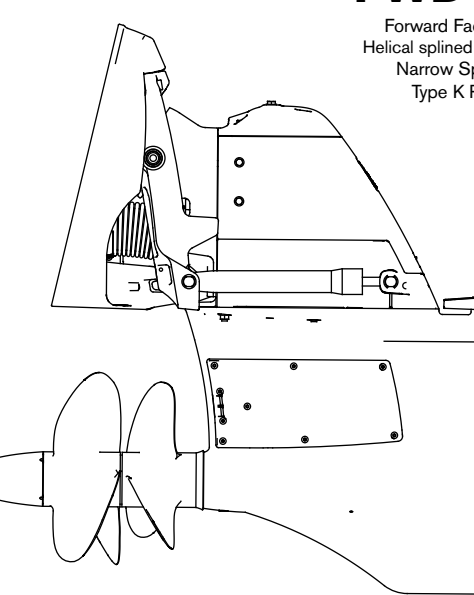

Ratio:
2.14:1
2.32:1

Oil:
Synthetic Gear Oil
API GL-5 SAE 75W-90
Qty: 2.8 liters (3.0 US qts)

FWD-D1

Silent Shift
Helical splined propshaft
Narrow Spray Plate
Type K Propellers

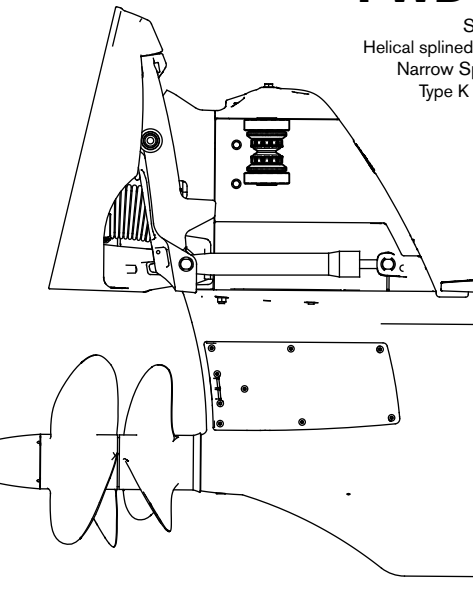

Ratio:
1.95:1
2.14:1
2.32:1

Oil:
Synthetic Gear Oil
API GL-5 SAE 75W-90
Qty: 2.8 liters (3.0 US qts)

FWD-D2

Silent Shift
Helical splined propshaft
Narrow Spray Plate
Type K Propellers

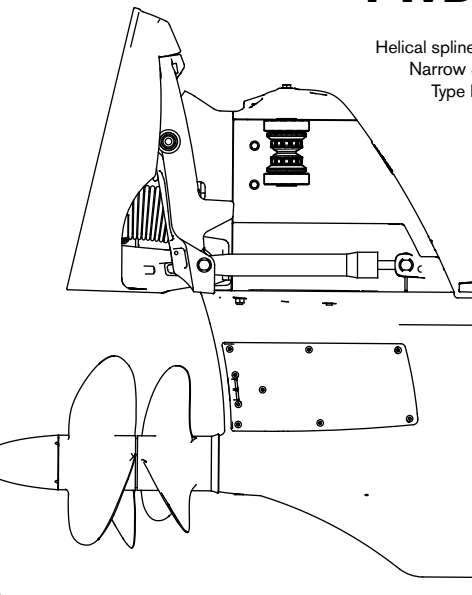

Ratio:
2.14:1
2.32:1

Oil:
Synthetic Gear Oil
API GL-5 SAE 75W-90
Qty: 2.8 liters (3.0 US qts)

DPH-A

High feature drive
Diesel applications
Hydraulic Steering
Type G or H Propellers

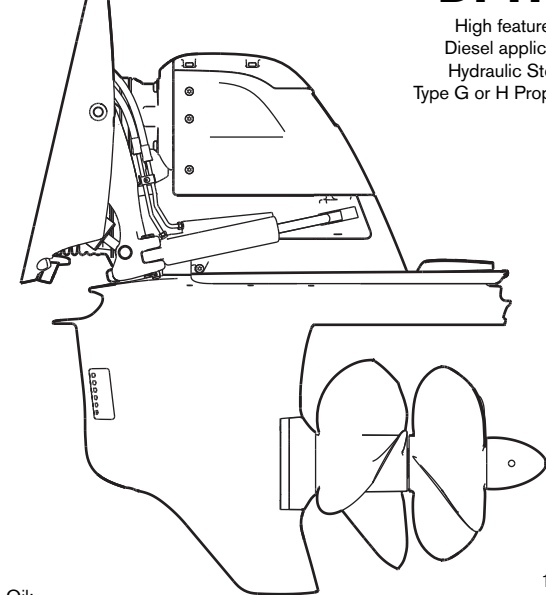

Ratio:
1.63:1
1.96:1
1.76:1
1.85:1
2.08:1

Oil:
Synthetic Gear Oil
API GL-5 SAE 75W-90
Qty: 5.4 liters (5.7 US qts)

DPH-C

Diesel applications
Hydraulic steering
Type G or H Propellers

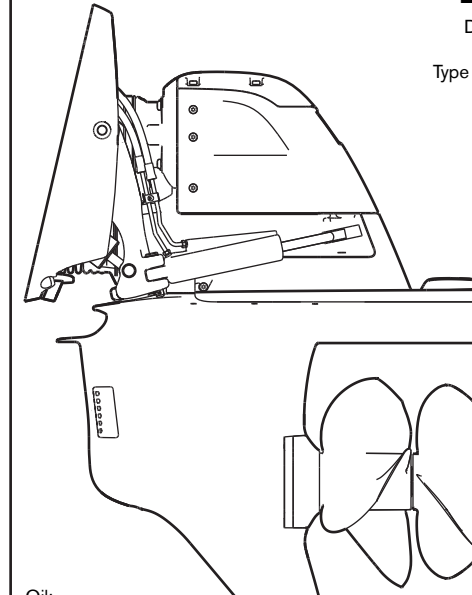

Ratio:
1.63:1
1.96:1
1.76:1
1.85:1
2.08:1

Oil:
Synthetic Gear Oil
API GL-5 SAE 75W-90
Qty: 5.2 liters (5.4 US qts)

DPH-D1

Diesel applications
Hydraulic steering
Type G or H Propellers

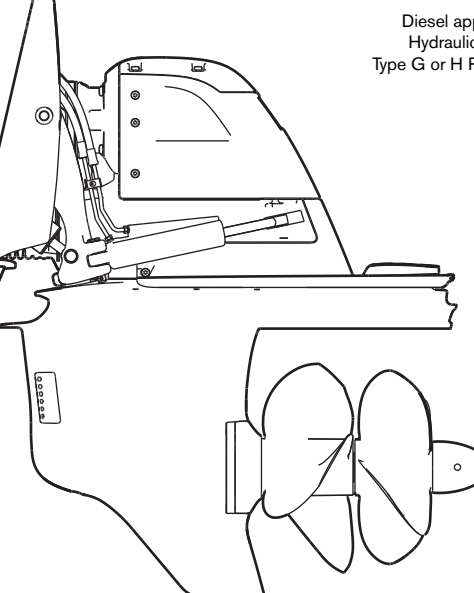

Ratio:
1.59:1
1.63:1
1.69:1
1.76:1
1.85:1
1.96:1
2.08:1

Oil:
Synthetic Gear Oil
API GL-5 SAE 75W-90
Qty: 5.1 liters (5.3 US qts)

DPH-E

Diesel applications
Hydraulic steering
Type G or H Propellers

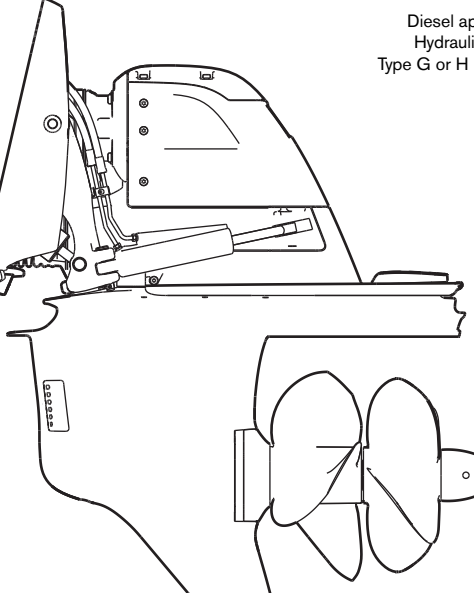

Ratio:
1.59:1
1.63:1
1.69:1
1.76:1
1.85:1
1.96:1
2.08:1

Oil:
Synthetic Gear Oil
API GL-5 SAE 75W-90
Qty: 5.1 liters (5.3 US qts)

DPR-A

High performance drive
Diesel applications
Type GR Propellers

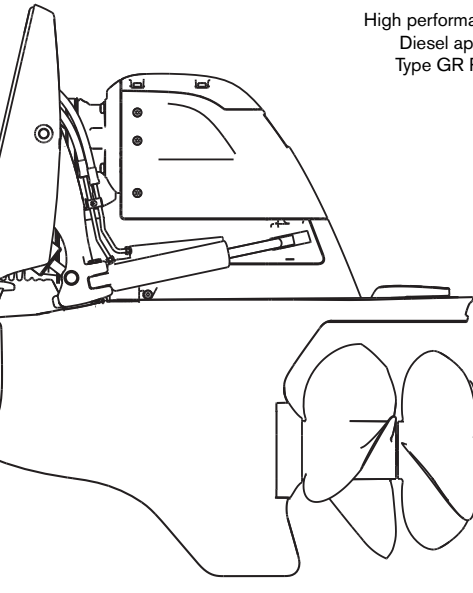

Ratio:
1.36:1
1.46:1

Oil:
Synthetic Gear Oil
API GL-5 SAE 75W-90
Qty: 4.2 liters (4.4 US qts)

DPR-C

High performance drive
Type GR Propellers

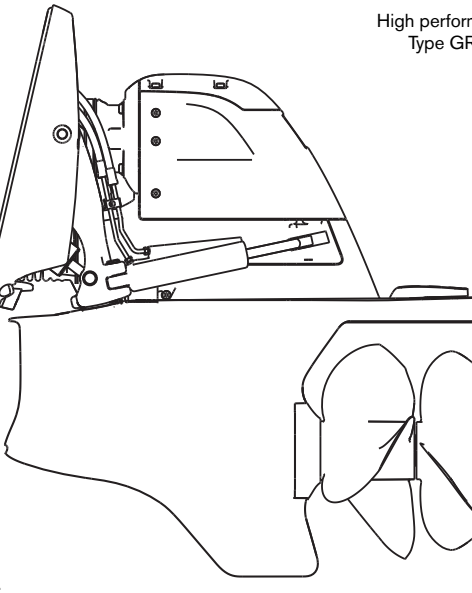

Ratio:
1.36:1
1.46:1

Oil:
Synthetic Gear Oil
API GL-5 SAE 75W-90
Qty: 4.2 liters (4.4 US qts)

DPR-D

High performance drive
Type GR propellers

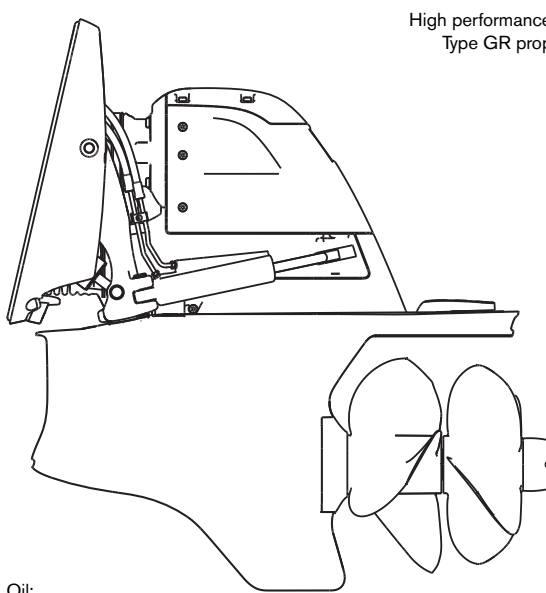

Ratio:
1.36:1
1.46:1

Oil:
Synthetic Gear Oil
API GL-5 SAE 75W-90
Qty: 4.2 liters (4.4 US qts)

DPI-A

Diesel Sterndrive
Hydraulic Shift
Hydraulic Steering
Type H propellers

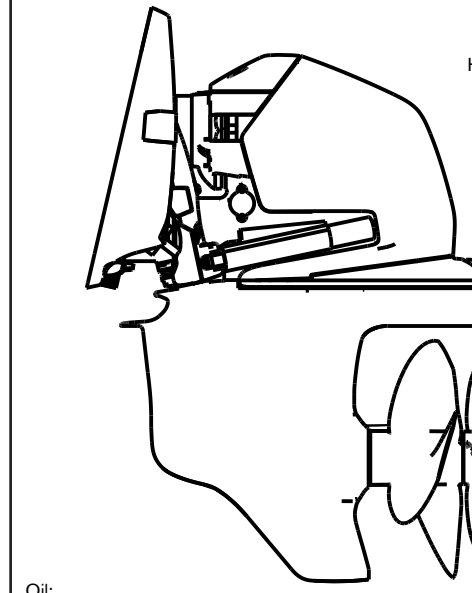

Ratio:
1.69:1
1.85:1

Oil:
Synthetic Gear Oil
API GL-5 SAE 75W-90
Qty: 5.8 liters (6.12 US qts)

Oil and grease specifications

| Type | Grade | Viscosity | Quantity-US | Part no. US |
|------------------|--------|-------------|-------------|-------------|
| Gear oil | GL-5 | SAE 90 | 1 US qt | 3855834-2 |
| Gear oil | GL-5 | SAE 90 | 1 US gal | 3855836-7 |
| Gear oil | GL-5 | SAE 90 | N/A | N/A |
| Syn Gear Oil | GL-5 | SAE 75W-90 | 1 US qt | 3851128-3 |
| Syn Gear Oil | GL-5 | SAE 75W-90 | 1 US gal | 3851129-1 |
| Syn Gear Oil | GL-5 | SAE 75W-90 | 5 US gal | 3851133-3 |
| Syn Gear Oil | GL-5 | SAE 75W-140 | 0.26 US gal | 1141666-6 |
| Syn Gear Oil | GL-5 | SAE 75W-140 | 1.30 US gal | 1141667-4 |
| Syn Gear Oil | GL-5 | SAE 75W-140 | 5.30 US gal | 1141668-2 |
| Grease | NLGI 2 | | 0.95 oz | 828250-1 |
| Propshaft grease | NLGI 4 | | 17.6 oz | 1141644-3 |

| Type | Grade | Viscosity | Quantity-Metric | Part no. ROW |
|------------------|--------|-------------|-----------------|--------------|
| Gear oil | GL-5 | SAE 90 | 1 liter | 1141637-7 |
| Gear oil | GL-5 | SAE 90 | 5 liter | 1141638-5 |
| Gear oil | GL-5 | SAE 90 | 20 liter | 1141639-3 |
| Syn Gear Oil | GL-5 | SAE 75W-90 | 1 liter | 1141634 |
| Syn Gear Oil | GL-5 | SAE 75W-90 | 5 liter | 1141635 |
| Syn Gear Oil | GL-5 | SAE 75W-90 | 20 liter | 1141636 |
| Syn Gear Oil | GL-5 | SAE 75W-140 | 1 liter | 1141666-6 |
| Syn Gear Oil | GL-5 | SAE 75W-140 | 5 liter | 1141667-4 |
| Syn Gear Oil | GL-5 | SAE 75W-140 | 20 liter | 1141668-2 |
| Grease | NLGI 2 | | 27 g | 828250-1 |
| Propshaft grease | NLGI 4 | | 500 g | 1141644-3 |

1) NOTE! If the drive was manufactured before 1986, for a 30- or 40- series engines and has previously been operated with engine oil in the drive, engine oil should continue to be used in future.