

**RB**

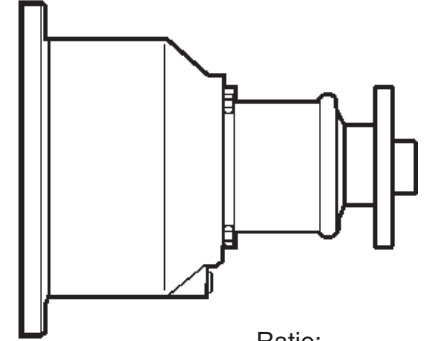

Oil: Common with engine  
Qty: Common with engine

Ratio: 1.87:1  
3.42:1 (with additional gear)

**RB**  
Gear shift lever

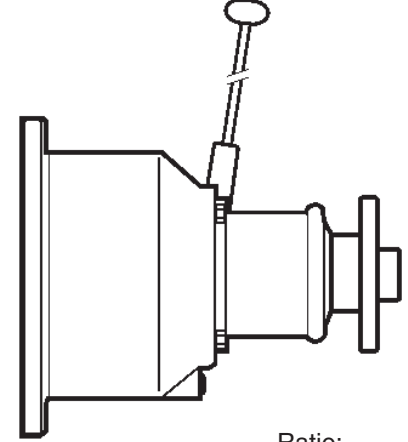

Oil: Common with engine  
Qty: Common with engine

Ratio: 1.87:1  
3.42:1 (with additional gear)

**MS**

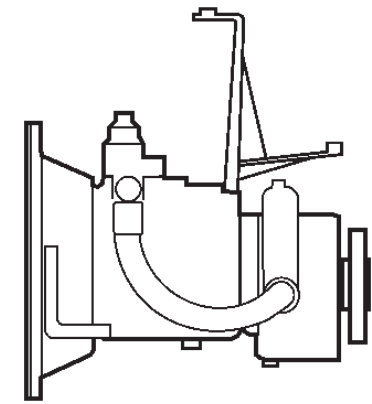

Oil: Same as engine  
Qty: 0.60 liters (0.63 US qts)

Ratio: 1:1  
1.91:1

**MSB**  
Cone with lining

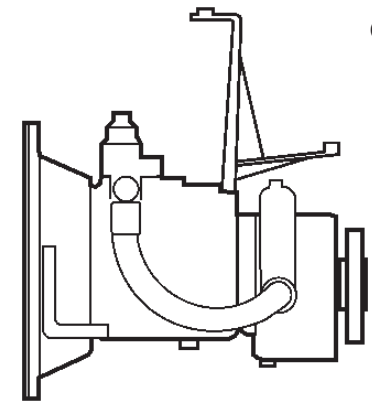

Oil: Same as engine  
Qty: 0.6 liters (0.63 US qts)

Ratio: 1:1  
1.91:1

**MS2**  
**MS2B-A**

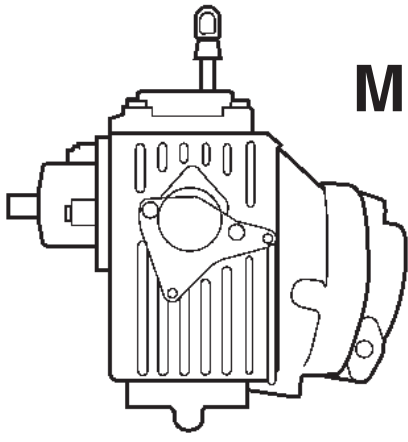

Oil: Same as engine  
Qty: 0.8 liters (0.85 US qts)

Ratio: 2.37:1  
3.02:1

**MS2B-L**

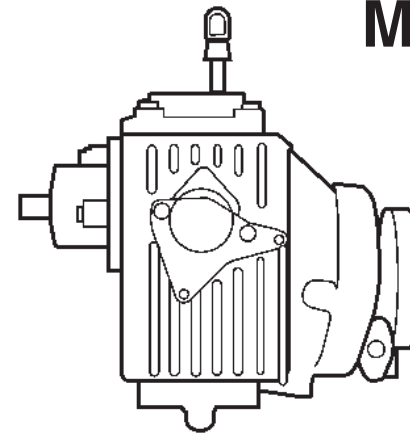

Oil: Same as engine  
Qty: 0.8 liters (0.85 US qts)

Ratio: 2.30:1

**MS2A-D**

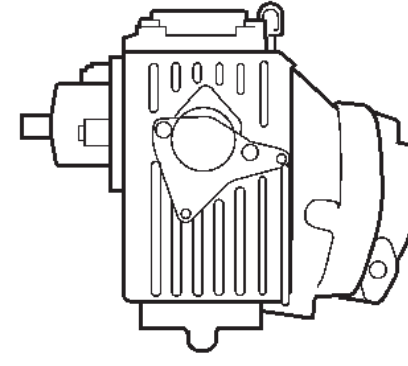

Oil: Same as engine  
Qty: 0.8 liters (0.85 US qts)

Ratio: 2.40:1  
3.00:1

**MS2L-D**

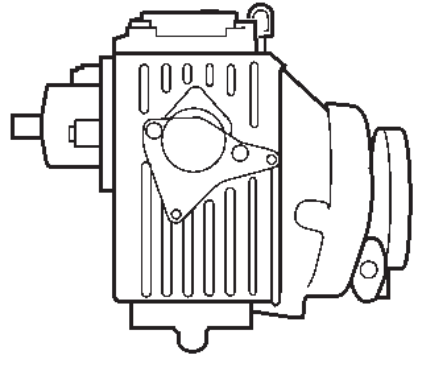

Oil: Same as engine  
Qty: 0.8 liters (0.85 US qts)

Ratio: 2.30:1

**MS2A-E**  
Shot blasted gear wheels

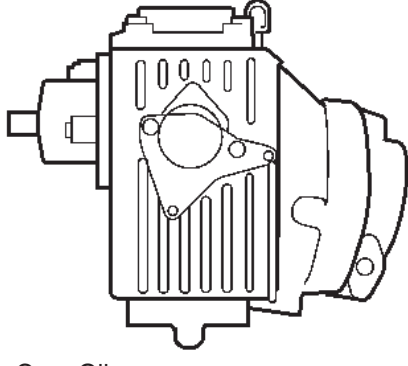

Oil: Synthetic Gear Oil  
API GL-5, SAE 75W/90  
Qty: 0.8 liters (0.85 US qts)

Ratio: 2.40:1  
3.00:1

**MS2L-E**  
Shot blasted gear wheels

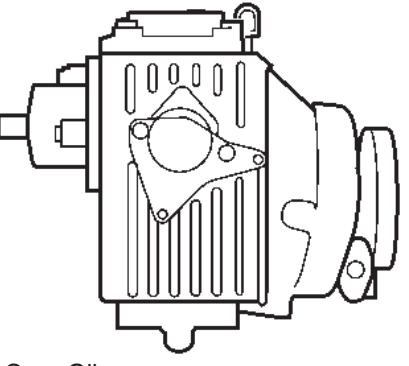

Oil: Synthetic Gear Oil  
API GL-5, SAE 75W/90  
Qty: 0.8 liters (0.85 US qts)

Ratio: 2.30:1

**MS2V**  
V-drive

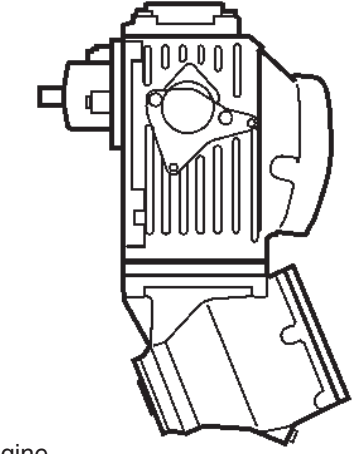

Oil: Same as engine  
Qty: 1.8 liters (1.90 US qts)

Ratio: 2.40:1  
3.00:1

**MS3**  
**MS3B**  
**MS3C**

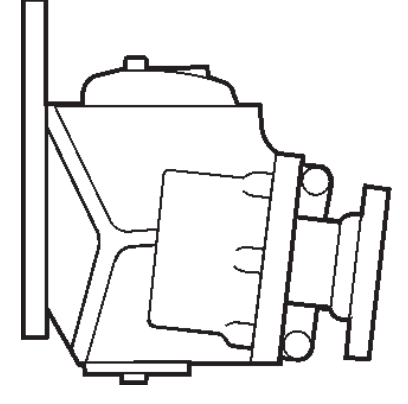

Oil: Same as engine  
Qty: 1.6 liters (1.69 US qts)

Ratio: 1.54:1  
1.93:1  
MS3C, 2.73:1  
2.91:1

**MS4A**

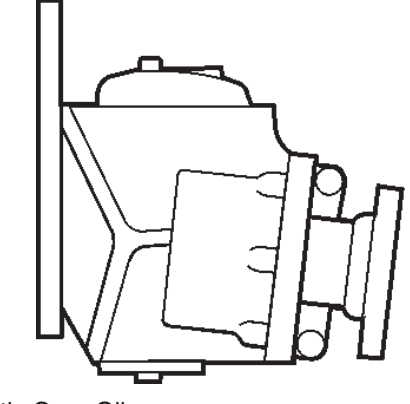

Oil: Synthetic Gear Oil  
API GL-5, SAE 75W/90  
Qty: 1.7 liters (1.79 US qts)

Ratio: 1.54:1  
1.94:1  
2.63:1

**MS4B**  
Integrated bearing, upper gear wheel

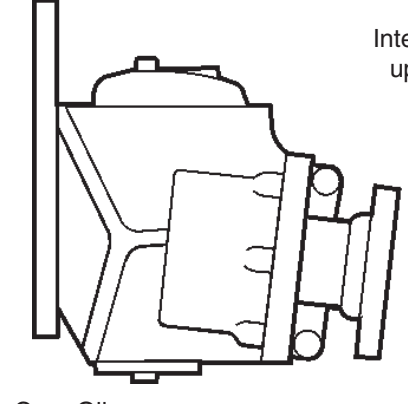

Oil: Synthetic Gear Oil  
API GL-5, SAE 75W/90  
Qty: 1.7 liters (1.79 US qts)

Ratio: 1.54:1  
1.94:1  
2.63:1

**MS5A/B<sup>1</sup>**  
1) Integrated bearing, upper gear wheel

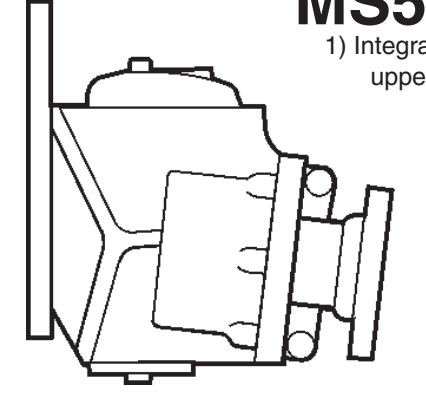

Oil: Synthetic Gear Oil  
API GL-5, SAE 75W/90  
Qty: 1.7 liters (1.79 US US qts)

Ratio: 1.55:1  
1.94:1  
2.40:1

**MS5C**  
Integrated bearing, upper gear wheel  
Resilient sliding sleeve

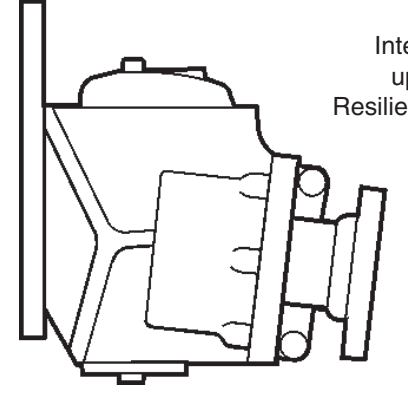

Oil: Synthetic Gear Oil  
API GL-5, SAE 75W/90  
Qty: 1.7 liters (1.79 US qts)

Ratio: 1.94:1  
2.40:1

**MS4/5**  
Spare part unit

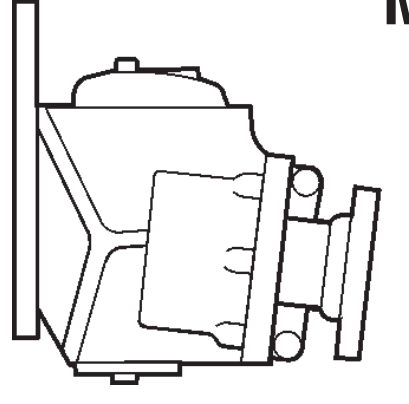

Oil: Synthetic Gear Oil  
API GL-5, SAE 75W/90  
Qty: 1.7 liters (1.79 US qts)

Ratio: 1.55:1  
1.94:1  
2.40:1  
2.63:1

**MS10A**

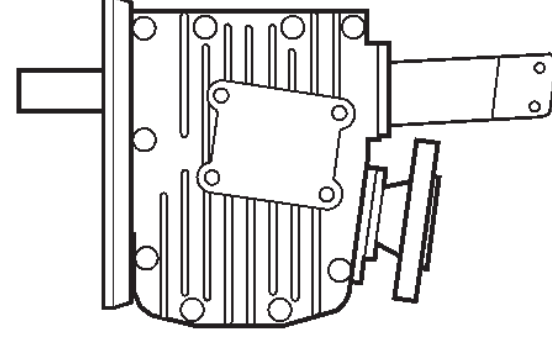

Oil: Same as engine  
Qty: 0.4 liters (0.42 US qts)

Ratio: 2.35:1  
2.72:1

**MS10A-B**

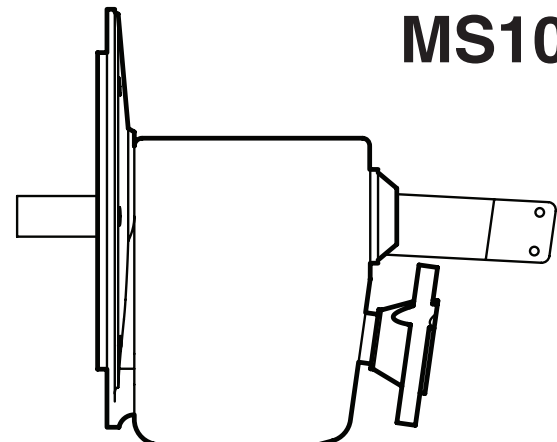

Oil: Same as engine  
Qty: 0.4 liters (0.42 US qts)

Ratio: 2.35:1  
2.72:1

**MS10L**

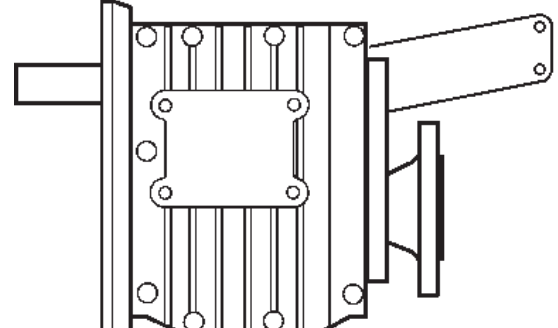

Oil: Same as engine  
Qty: 0.42 liters (0.44 US qts)

Ratio: 2.35:1  
2.72:1

**MS10L-B**

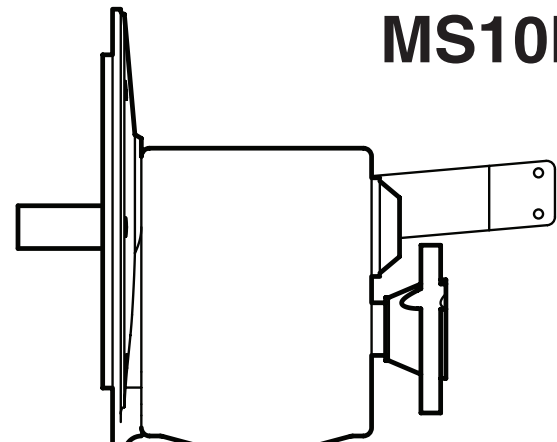

Oil: Same as engine  
Qty: 0.42 liters (0.44 US qts)

Ratio: 2.35:1  
2.72:1

**MS15A**

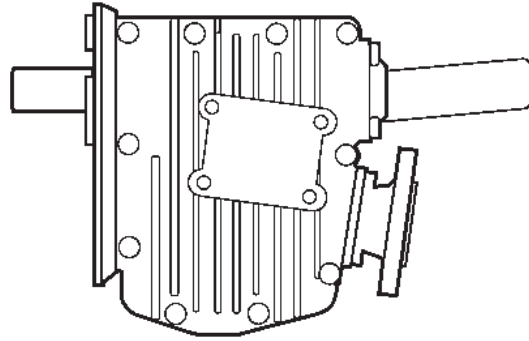

Oil: Same as engine  
Qty: 0.56 liters (0.59 US qts)

Ratio: 2.14:1  
2.63:1

**MS15A-B**

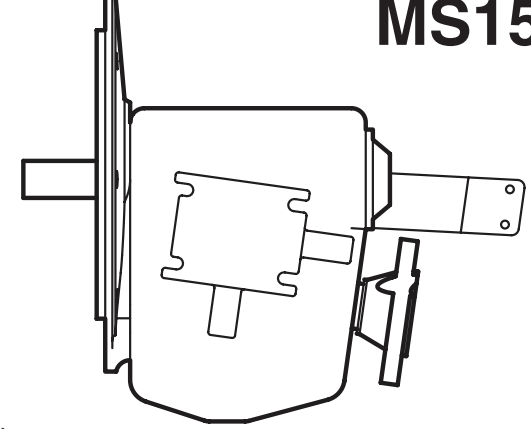

Oil: Same as engine  
Qty: 0.56 liters (0.59 US qts)

Ratio: 2.14:1  
2.63:1

**MS15L**

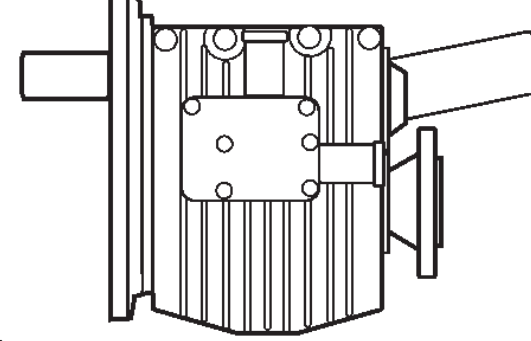

Oil: Same as engine  
Qty: 0.6 liters (0.63 US qts)

Ratio: 2.14:1  
2.63:1

**MS15L-B**

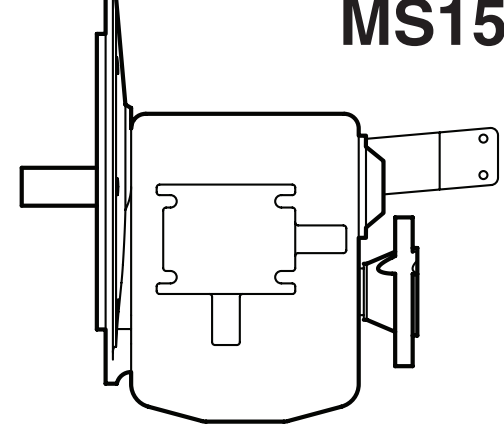

Oil: Same as engine  
Qty: 0.6 liters (0.63 US qts)

Ratio: 2.14:1  
2.63:1

**MS25A**

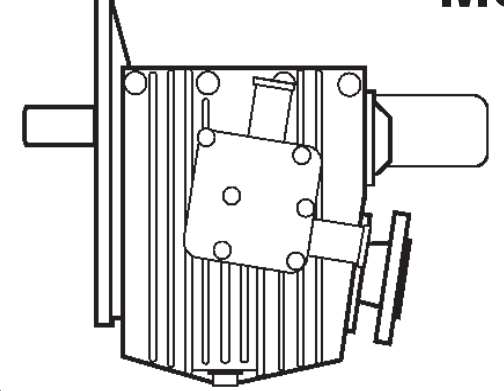

Oil: Same as engine  
Qty: 0.75 liters (0.79 US qts)

Ratio: 2.27:1  
2.74:1

**MS25L**

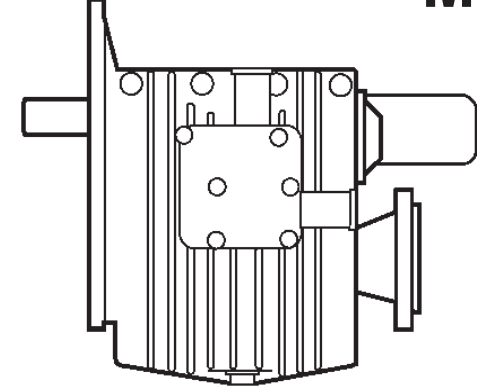

Oil: Same as engine  
Qty: 0.75 liters (0.79 US qts)

Ratio: 2.27:1  
2.74:1

**HS1**  
**HS1A**

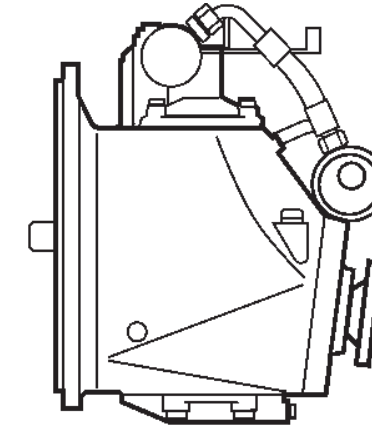

Oil: Same as engine  
Qty: 3.0 liters (3.17 US qts)

Ratio: 1.96:1  
2.62:1

**HS1E-A**  
Electric gear shift

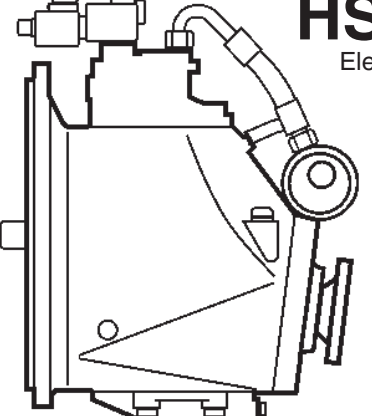

Oil: Same as engine  
Qty: 3.0 liters (3.17 US qts)

Ratio: 1.96:1  
2.62:1

**HS25A**

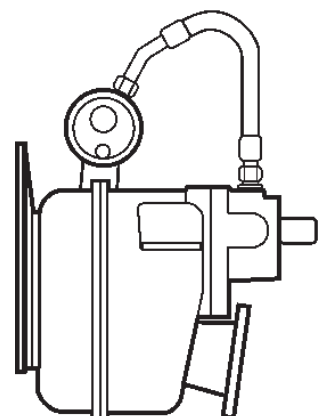

Oil: Automatic Transmission Fluid (ATF) Dexron II/III  
Qty: 1.8 liters (1.90 US qts)

Ratio: 2.29:1  
2.71:1

**HS45A**

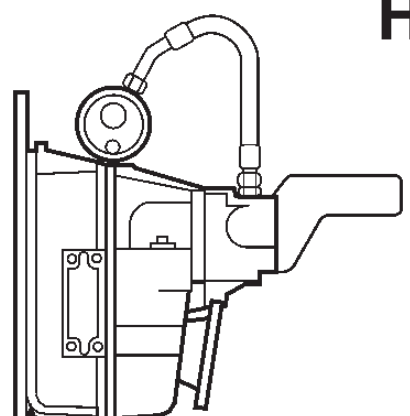

Oil: Automatic Transmission Fluid (ATF) Dexron II/III  
Qty: 2.5 liters (2.64 US qts)

Ratio: 1.51:1  
2.03:1  
2.43:1

**HS45AE/-B<sup>2</sup>**  
2) For Lowspeed

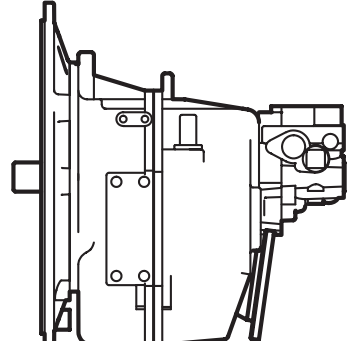

Oil: Automatic Transmission Fluid (ATF) Dexron II/III  
Qty: 2.5 liters (2.64 US qts)

Ratio: 1.51:1  
2.03:1  
2.43:1

**HS63A**

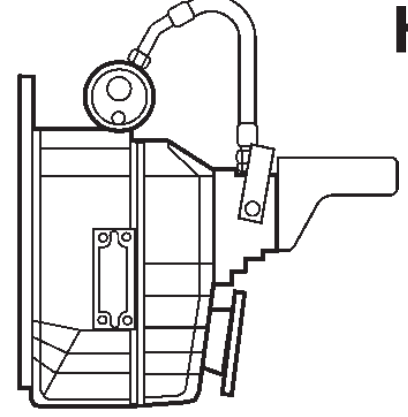

Oil: Automatic Transmission Fluid (ATF) Dexron II/III  
Qty: 3.8 liters (4.02 US qts)

Ratio: 1.56:1  
2.04:1  
2.52:1

**HS63AE**  
Electric gear shift

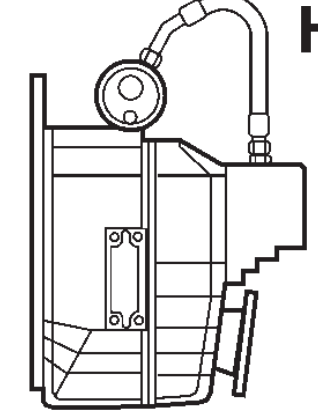

Oil: Automatic Transmission Fluid (ATF) Dexron II/III  
Qty: 3.8 liters (4.02 US qts)

Ratio: 1.56:1  
2.04:1  
2.52:1

**HS63AE-B/-C<sup>3</sup>**  
Electric gear shift  
3) For Lowspeed

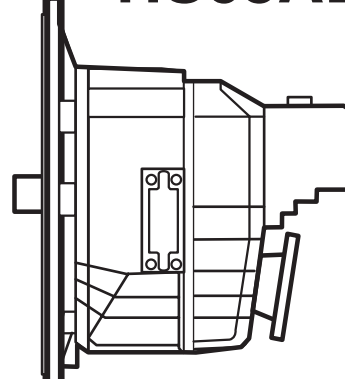

Oil: Automatic Transmission Fluid (ATF) Dexron II/III  
Qty: 3.8 liters (4.02 US qts)

Ratio: 1.56:1  
2.00:1  
2.52:1

**HS63V**  
V-drive

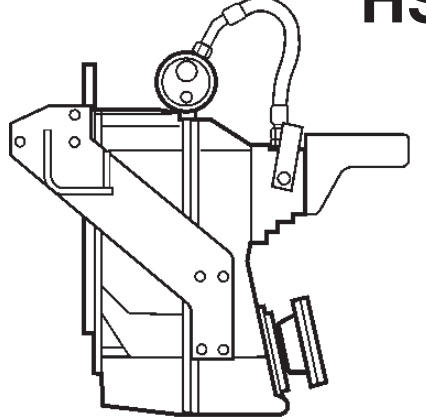

Oil: Automatic Transmission Fluid (ATF) Dexron II/III  
Qty: 4.3 liters (4.54 US qts)

Ratio: 1.56:1  
1.99:1  
2.48:1

**HS63VE**  
V-drive  
Electric gear shift

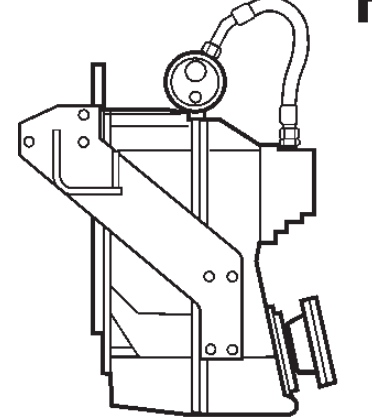

Oil: Automatic Transmission Fluid (ATF) Dexron II/III  
Qty: 4.3 liters (4.54 US qts)

Ratio: 1.56:1  
1.99:1  
2.48:1

**HS63IVE-A/-B<sup>4</sup>**  
4) For Lowspeed

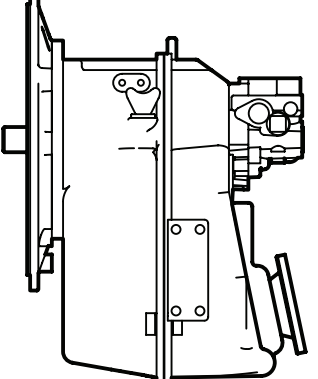

Oil: Automatic Transmission Fluid (ATF) Dexron II/III  
Qty: 3.8 liters (4.02 US qts)

Ratio: 1.56:1  
1.99:1  
2.48:1

**HS80AE-A/-B<sup>5</sup>**  
**HS85AE-A<sup>5</sup>**  
5) For Lowspeed

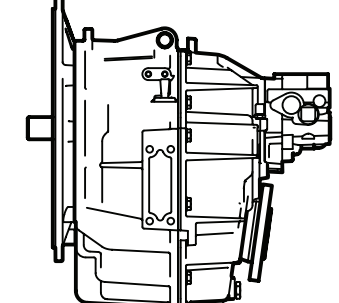

Oil: Automatic Transmission Fluid (ATF) Dexron II/III  
Qty: 5 liters (5.28 US qts), 4) 5.5 liters (5.81 US qts)

Ratio: 1.57:1  
1.96:1  
2.50:1

**HS80IVE-A/-B<sup>6</sup>**  
**HS85IVE-A<sup>6</sup>**  
6) For Lowspeed

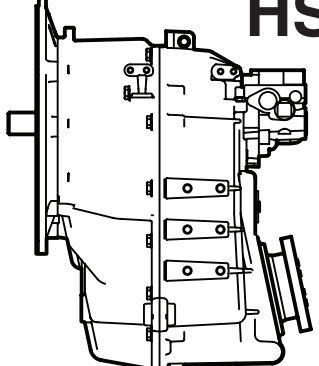

Oil: Automatic Transmission Fluid (ATF) Dexron II/III  
Qty: 7 liters (7.4 US qts)

Ratio: 1.64:1  
2.01:1  
2.49:1

**Oil specifications**

| Type of oil         | Grade    | Viscosity  | Quantity | Part no. | Quantity US | Part no. US |
|---------------------|----------|------------|----------|----------|-------------|-------------|
| Synthetic Gear Oil  | API GL-5 | SAE 75W-90 | 1 liter  | 3809443  | 1 US qt     | 1141679     |
| Synthetic Gear Oil  | API GL-5 | SAE 75W-90 | 5 liter  | 3809442  | 1 US gal    | 1141677     |
| Synthetic Gear Oil  | API GL-5 | SAE 75W-90 | 20 liter | 3809441  | 5 US gal    | 1141681     |
| ATF-Oil Dextron III |          |            | 1 liter  | 1161521  |             |             |
| ATF-Oil Dextron III |          |            | 5 liter  | 1161995  |             |             |

**NOTE!** Never mix oil qualities when topping up.

**VOLVO PENTA**